



ADDENDUM II

BLOOMINGTON CITY COUNCIL AGENDA

SEPTEMBER 9, 2013

ADDITION TO CONSENT AGENDA

Item 7C. Appointments to the Property Maintenance Review Board. (Recommend that the Appointments and Reappointments be approved.)

Item 7L. *Attachment 12. Plat*

FOX CREEK VILLAGE PLANNED UNIT DEVELOPMENT AMENDED PRELIMINARY DEVELOPMENT PLAN BLOOMINGTON, ILLINOIS

Notes:

- 1) The site is zoned R-2 and contains 26.25 acres. The property includes an existing clubhouse and 28 existing condominium type ownership units. Lots 1 through 122 contain 117 single family homes. Outlots 25, 59, 123, 124 & 125 contain off-street parking areas. Outlots 126 & 127 to be open Recreation Space owned by Homeowners Association.
 - 2) All proposed streets will be platted as private streets and maintained by a homeowner's association.
 - 3) All sanitary sewer, storm sewer, and water main shall be built within easements and dedicated to the City of Bloomington. Drains shall be private and contained in easements and maintained by the homeowner's association.
 - 4) All off-street parking areas will be platted as outlots and maintained by a homeowner's association.
 - 5) Storm water detention is provided by an existing detention basin along the south boundary of the site by annexation agreement.
 - 6) No portion of this property lies within the special flood hazard zone.
 - 7) Topography is from Farnsworth Group field survey dated March, 1994.
 - 8) Parkland dedication has been previously satisfied by dedication of The Den at Fox Creek Golf Course.
 - 9) Minimum distance between buildings shall be 12'.
 - 10) All buildings shall be served by a sump pump discharge connected to the storm sewer system.
 - 11) Each residential building shall have a two car attached garage. 35 additional guest parking spaces are provided at various locations shown on the plan. Streets shall be posted No Parking.
 - 12) All areas within the private streets to the building setback lines shall be dedicated as utility easements.
 - 13) Density, floor area, open space, and common recreational space for this site area as follows:

Ratio	City Code	145 Units * (as shown)
Net density (units/acre)	10.0 Max.	5.52
Floor area (% of land area)	40.0 % of Max.	29.0%
Open Space (% of land area)	72.0% Min.	72%
Common Recreation Space (% of land area)	5.2% Min.	N/A
 - 14) The Homeowners Association has the right to Re-plot lot 19 into private street R.O.W. & Outlot 127 & construct a private street connection to Rutherford Drive as shown on the plan.
 - 15) Sidewalk on lots 47, 52-55 & 100-122 to be built by developer or homebuilder as part of this development. Sidewalks on lots 20-24 & outlots 25, 59, & 127 may be constructed in the future by others. All sidewalks to be owned & maintained by Homeowners Association.
 - 16) City of Bloomington is granted the right to construct a future emergency vehicle access across Outlot 126.
- * Does not include lot 19 see note 14.
- Waivers:**
- 1) Cul-de-sac length as shown shall exceed 15 lots fronting thereon.

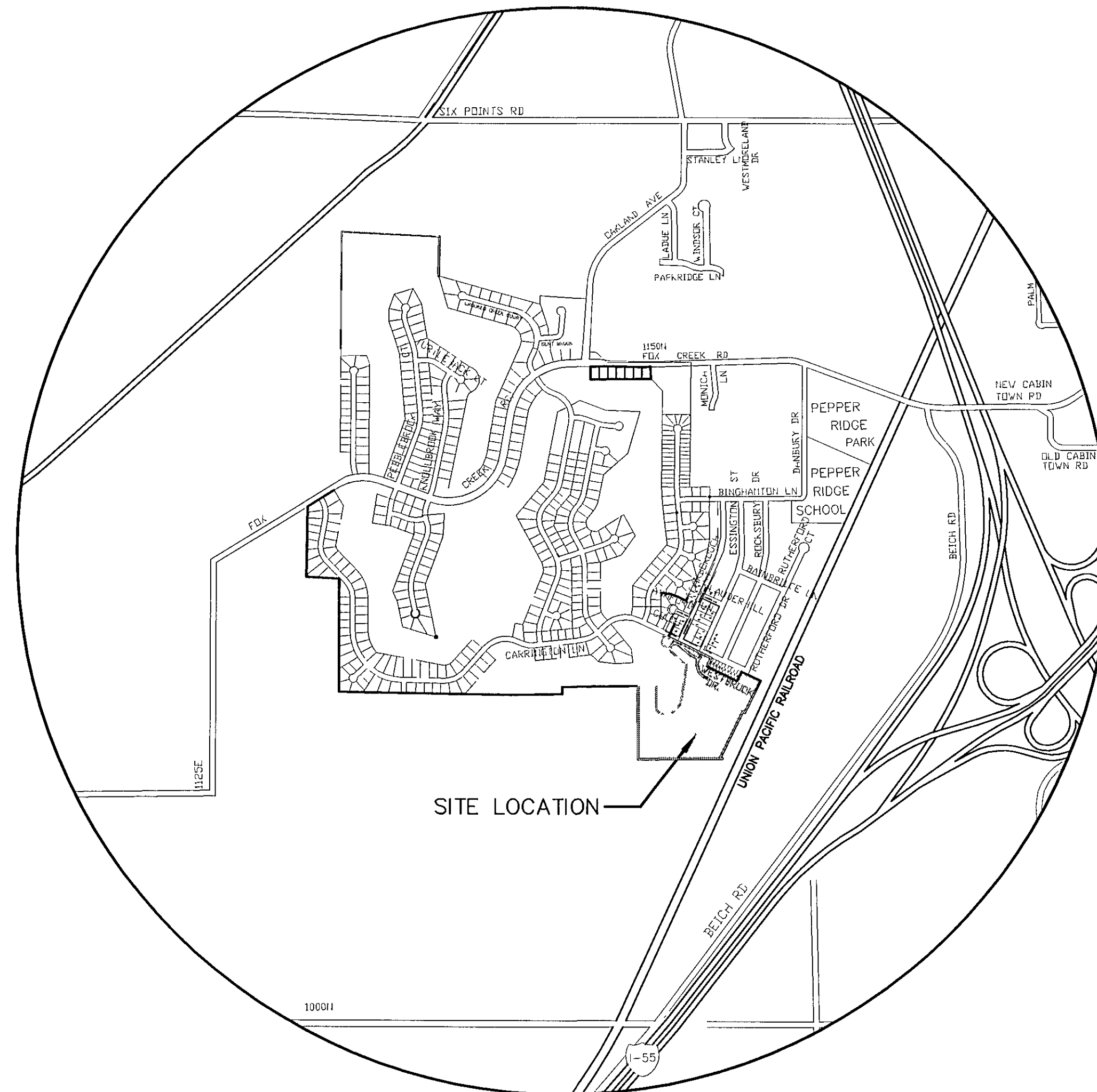

LOCATION MAP



BENCHMARKS:

1. TOP OF FIRE HYDRANT N.W. COR WESTBROOK & WINDING WAY
U.S.G.S. ELEV.=773.85
2. TOP OF FIRE HYDRANT AT NN.E.COR ROCKBURY & WINDING WAY
U.S.G.S. ELEV.=784.84



INDEX TO SHEETS

SHEET NO.	TITLE
1	COVER SHEET
2	KEY MAP
3-4	PRELIMINARY DEVELOPMENT PLAN

OWNER/DEVELOPER

FOX CREEK VILLAGE, LLC
c/o STEVE SNYDER
#1 BRICKYARD DRIVE
BLOOMINGTON, ILLINOIS 61701
(309) 664-1880

ATTORNEY

CLAY COX
COX & ASSOCIATES, LLC
202 N. CENTER
BLOOMINGTON, ILLINOIS 61701
(309) 828-7331

ENGINEER

DONALD L. ADAMS, P.E.
FARNSWORTH GROUP
2709 MCGRAW DRIVE
BLOOMINGTON, ILLINOIS 61704
(309) 663-8435

RECOMMENDATION OF AMENDED PRELIMINARY DEVELOPMENT PLAN APPROVAL BY THE PLANNING COMMISSION OF BLOOMINGTON, ILLINOIS.

"Notice is hereby given that this Amended Preliminary Development Plan of Fox Creek Village shown hereon is recommended by the Planning Commission of Bloomington, Illinois, for City Council approval with the modifications contained in Appendix A (if any), which is attached hereto."

The Planning Commission of Bloomington, Illinois
Date: _____, 2013
By: _____
Chairman
By: _____
Executive Secretary

NOTICE OF APPROVAL OF PRELIMINARY DEVELOPMENT PLAN BY THE CITY COUNCIL OF BLOOMINGTON, ILLINOIS:

"The Amended Preliminary Development Plan of Fox Creek Village shown hereon has received approval by the City Council of Bloomington, Illinois, subject to the modifications contained in Appendix A which is attached hereto."

The City Council of Bloomington, Illinois
Date: _____, 2013
By: _____
Mayor

Attest:

City Clerk

JOINT UTILITY LOCATION INFORMATION FOR EXCAVATORS: CONTRACTORS SHALL CALL THE TOLL FREE J.U.L.I.E. TELEPHONE NUMBER, 1-800-892-0123, BEFORE STARTING EXCAVATION. ALLOW 48 HOURS FOR OTHER THAN EMERGENCY ASSISTANCE.

Revisions	Incls	DESIGNED BY	<p>2709 MCGRAW DRIVE BLOOMINGTON, ILLINOIS 61704 (309) 663-8435 / (309) 663-1571 Fax www.f-w.com</p>
1	5/14/03	RLW	
2	8/25/03	RLW	
3	5/15/13	SJB	
4	7/5/13	RLW	
5	7/22/13	EMR	
6			
7			
8			
9			
10			
11			
12			
13			
14			
15			
16			
17			
18			
19			
20			
21			
22			
23			
24			
25			
26			
27			
28			
29			
30			
31			
32			
33			
34			
35			
36			
37			
38			
39			
40			
41			
42			
43			
44			
45			
46			
47			
48			
49			
50			
51			
52			
53			
54			
55			
56			
57			
58			
59			
60			
61			
62			
63			
64			
65			
66			
67			
68			
69			
70			
71			
72			
73			
74			
75			
76			
77			
78			
79			
80			
81			
82			
83			
84			
85			
86			
87			
88			
89			
90			
91			
92			
93			
94			
95			
96			
97			
98			
99			
100			
101			
102			
103			
104			
105			
106			
107			
108			
109			
110			
111			
112			
113			
114			
115			
116			
117			
118			
119			
120			
121			
122			
123			
124			
125			
126			
127			
128			
129			
130			
131			
132			
133			
134			
135			
136			
137			
138			
139			
140			
141			
142			
143			
144			
145			
146			
147			
148			
149			
150			
151			
152			
153			
154			
155			
156			
157			
158			
159			
160			
161			
162			
163			
164			
165			
166			
167			
168			
169			
170			
171			
172			
173			
174			
175			
176			
177			
178			
179			
180			
181			
182			
183			
184			
185			
186			
187			
188			
189			
190			
191			
192			
193			
194			
195			
196			
197			
198			
199			
200			

FOX CREEK VILLAGE BLOOMINGTON, ILLINOIS PL-1141Z
COVER SHEET
Sheet No. 1 OF 4
Project No. 0130598.00 File No. 24-7084

N.W. 1/4 SEC. 19, T.23 N., R.2 E., 3 P.M.
& PT. SEC. 13 & 14, T.23 N., R.2 E., 3 P.M.

15

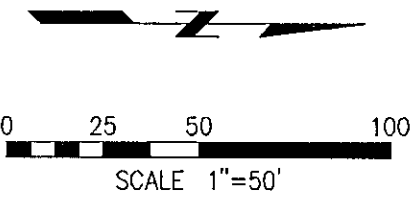

- LEGEND**
- EXISTING**
- IRON ROD
 - ▲ SIGN
 - FIRE HYDRANT
 - WATER VALVE
 - ⊙ LIGHT
 - ⊙ GAS METER
 - ⊙ ELECTRIC
 - ⊙ UNDERGROUND TELEPHONE PEDESTAL
 - ⊙ POWER POLE
 - ⊙ DOWN GUY
 - MANHOLE
 - INLET
 - ▬ STREET LIGHT
 - ▬ STORM SEWER
 - ▬ SANITARY SEWER
 - ▬ WATER MAIN
 - ▬ UNDERGROUND TELEPHONE LINE
 - ▬ OVERHEAD ELECTRIC LINE
 - ▬ GAS MAIN
 - ▬ GROUND CONTOUR
 - ▬ UTILITY EASEMENT LINE AS DIMENSIONED
 - ▬ 25' BUILDING SETBACK LINE
- PROPOSED**
- Ⓢ PAVEMENT ELEVATION
 - ⓐ INVERT ELEVATION
 - ⬢ GATE VALVE
 - ⬢ FIRE HYDRANT
 - MANHOLE OR INLET
 - ▲ CLEANOUT
 - ① NUMBER OF PARKING SPACES
 - ▬ CURB INLET
 - ▬ 8" W WATERMAIN
 - ▬ 8" S A SANITARY SEWER
 - ▬ 15" S T STORM SEWER
 - ▬ FLOOD ROUTE
 - ▬ 2.8% PAVEMENT SLOPE
 - ▲ STREET LIGHT



Xref files: \admin\ \data\ \vergo\ \update\ \vhl.w | \area check # 94 | \mp | \unit check 9-13-06 |
 | gromma | L | Fox creek subdivisions\fox creek village-new dnc | DATE: 01/30/2012 | TIME: 12:58 |

Revisions	Date	Initials
1	5/14/03	RLW
2	8/25/03	RLW
3	5/15/13	SJB
5	7/22/13	EMR

Farnsworth
GROUP

2709 McGRAW DRIVE
BLOOMINGTON, ILLINOIS 61704
(309) 663-8435 / (309) 663-1571 Fax
www.fw.com

FOX CREEK VILLAGE
BLOOMINGTON, ILLINOIS

PRELIMINARY
DEVELOPMENT PLAN

Drawn **RLW** Date **4-24-08**

Checked **DLA** Book No

Sheet No SHEET **3** OF **4**

Project No. **0130598.00** File No. **24-7084**

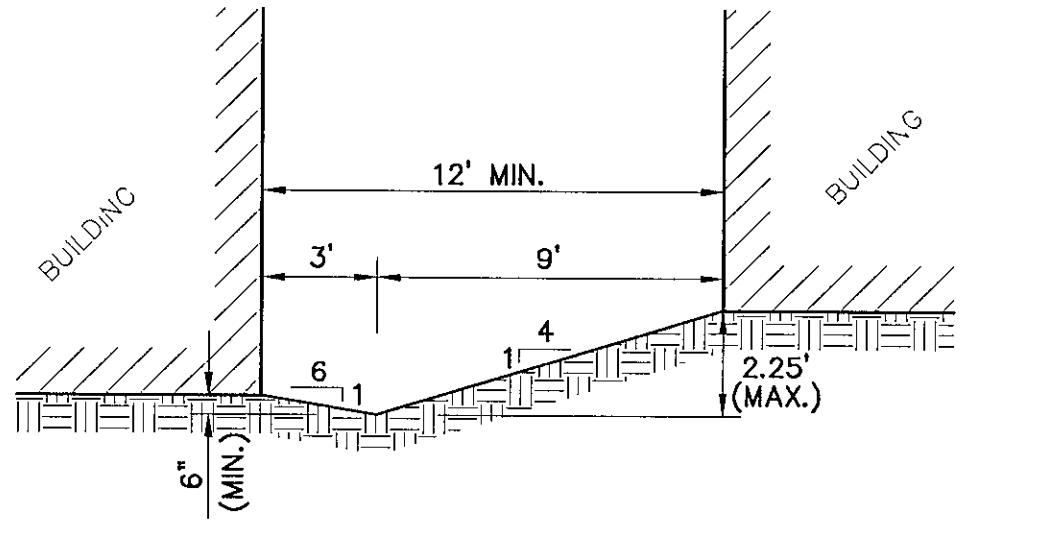
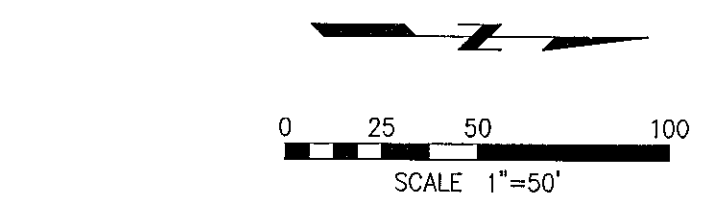

TYPICAL GRADING BETWEEN BUILDINGS

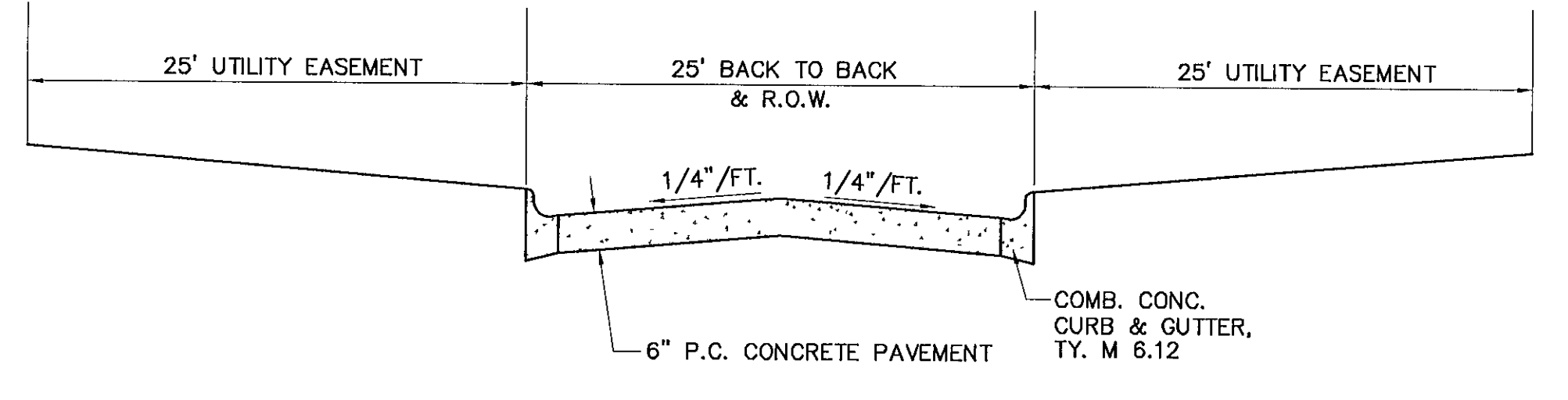

TYPICAL STREET SECTION

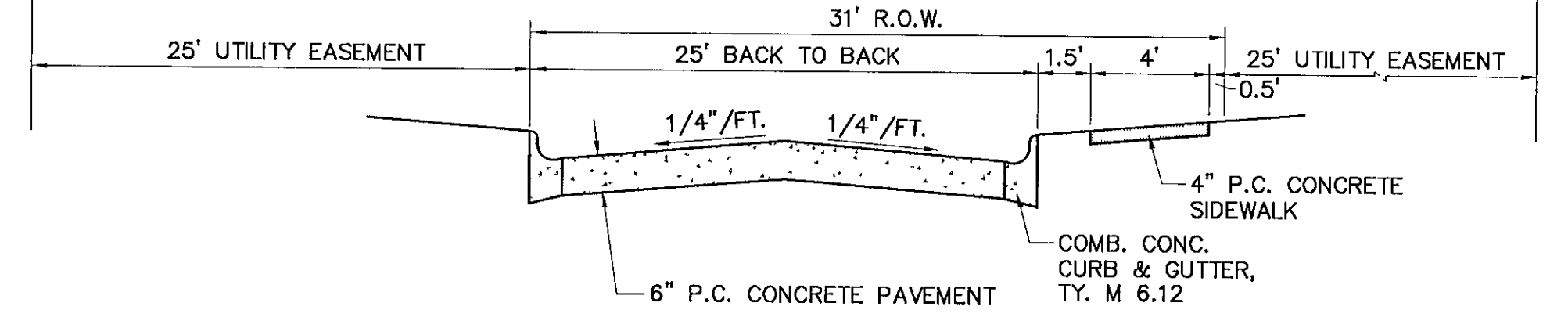

TYPICAL STREET SECTION WITH SIDEWALK

Xref files \source\plans\156_4\156_4.dwg | Auto check # 94 | Vmap | Vert. check 6-13-06 |
 | revision | 1 | Fox creek submissions\fox creek village\new dnc | DATE 07/30/2012 | time 15:58 |

Revisions	Date	Initials
1	5/14/13	RLW
2	8/25/03	RLW
3	5/15/13	SJB
4	7/5/13	RLW
5	7/22/13	EMR

Drawn	RLW	Date	4-24-03
Checked	DLA	Book No.	

Farnsworth GROUP

**FOX CREEK VILLAGE
BLOOMINGTON, ILLINOIS**

**PRELIMINARY
DEVELOPMENT PLAN**

2709 McGraw Drive
Bloomington, Illinois 61704
(309) 663-8435 / (309) 663-1571 Fax
www.f-w.com

Sheet No. SHEET **4** OF **4**

Project No **0130598.00** File No. **24-7084**